

# **Rapid Product Development Process**

Surveillance and Reconnaissance Systems

Falvey Malarcher

Falvey-Sr@raytheon.com

972-344 7078

## Problems Addressed

- **Reduce Embedded Algorithm Development Cost by 50%:**
  - **Simulation Cycles for performance metrics**
  - **Real-time execution demonstration metrics**
  - **Algorithms ready for embedded target qualification testing**

**NOTE: Processor Architecture includes: processor HW, interconnect HW, Operating System API SW, Message/Data IO API SW, Optimized Math/Vector/Matrix API SW.**

**API - Application Programming Interface**

**SRS - Surveillance & Reconnaissance Systems**

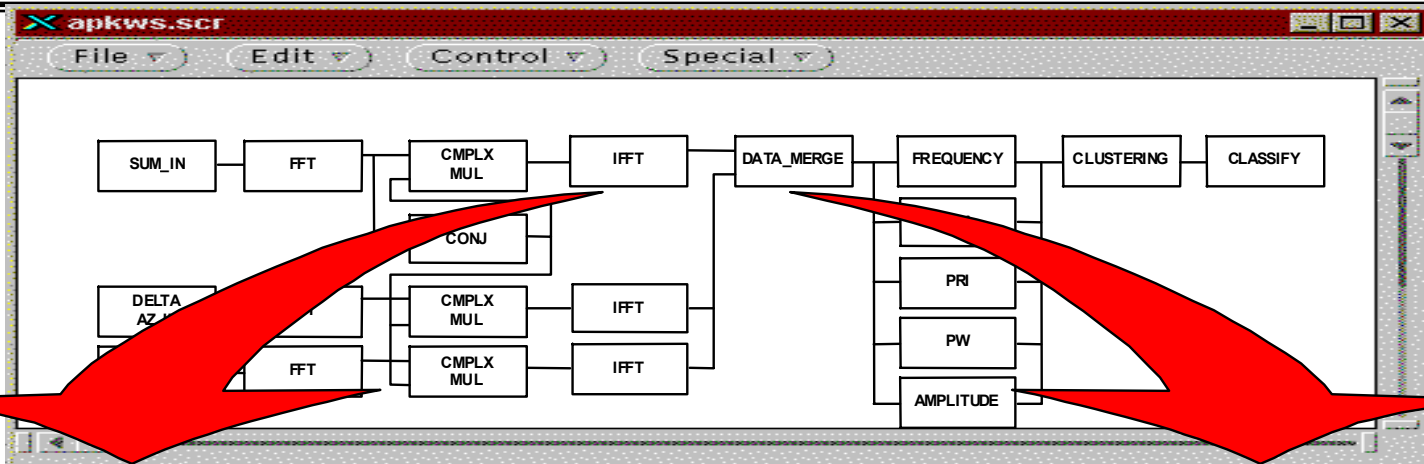

## RAPID PROTOTYPING ON UNIX PLATFORM

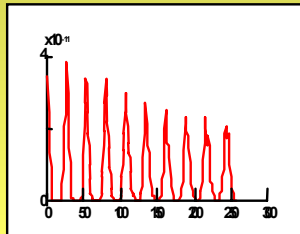

- Analyst Defines Signal Processing Flow Using Graphical Interface
- Modification of Software Components Interactively Allows Analyst to Tune System for Maximum Performance
- Data Recording at Any Point for off-Line Analysis

## “REAL TIME” SYSTEM PERFORMANCE IN LAB ENVIRONMENT

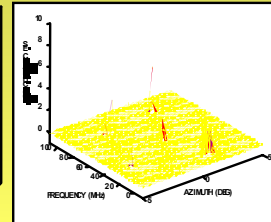
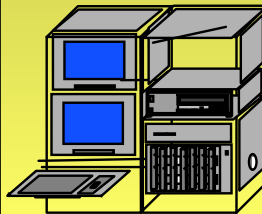

- Lab Utilizes Commercial Components
- Software Components Easily Reassigned to Processing Nodes to Optimize Throughput and Bus Loading

## PORTING TO ACTUAL TARGET SYSTEM WITHOUT REDEVELOPING SOFTWARE

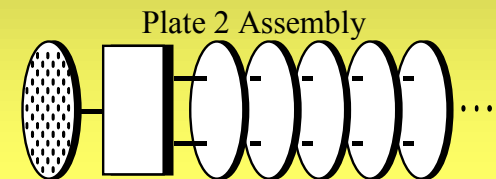

- Porting to Actual Target System without Redeveloping Software
- Computer in the Loop (CIL)

## RPD Process

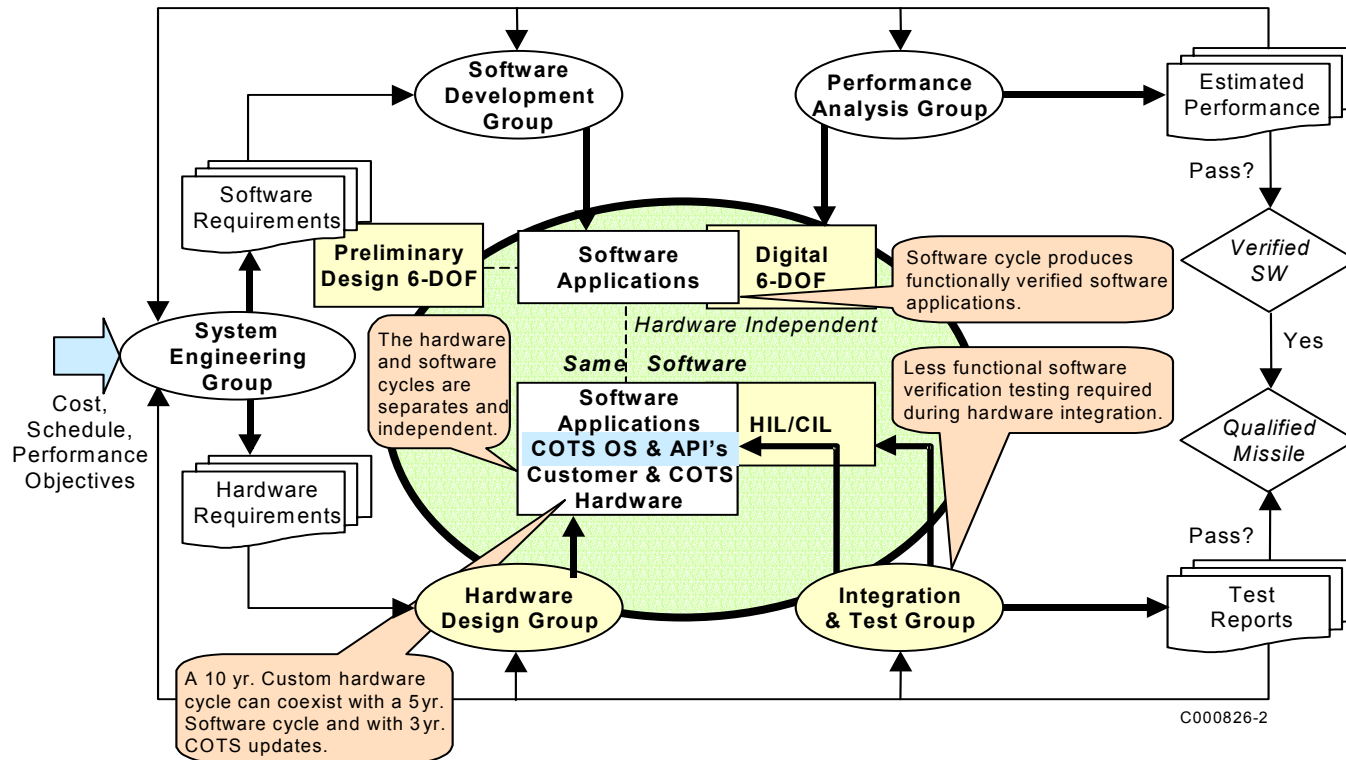

Process diagram taken from Johns Hopkins APL Proposal for Standard Missile software development process. This is an excellent description of the Algorithm/software RPD process.

**RPD Tool Concept**

**PROGRAM'S APPLICATION RPD TEAM PROVIDES**

**COTS RPD TOOL VENDOR PROVIDES**

**COTS PROCESSOR SYSTEM VENDOR PROVIDES**

**PROGRAM'S APPLICATION PROCESSING  
CUSTOM DRIVERS**

**COTS RPD TOOL**

**COTS PROCESSOR & IO INTERCONNECT HW**

**CUSTOM HW**

## RPD Enablers

- **The Application algorithm/software:**
  1. **must be usable by system engineers,**
  2. **must provide for development of parallel algorithms.**
- **RPD framework port provides efficient execution of the algorithm on specific processor architecture.**

## RPD Candidate Enablers

- **Orincon Technology's Rapid Interactive Parallel Programming Environment (RIPPEN)**
  - <http://www.rippen.com/>
- **Blue Horizon's GEDAE**
  - <http://www.gedae.com/>
- **I-Logix's Rhapsody & Statemate**
  - [http://www.ilogix.com/frame\\_flash.cfm](http://www.ilogix.com/frame_flash.cfm)
- **Rationale's Rose-RT**
  - <http://www.rational.com/products/rosert/index.jsp>
- **Honeywell's SAGE**
  - <http://www.honeywell.com/sage>
- **Artisansw's Real-Time Studio**
  - <http://www.artisansw.com/>
- **MCCI-ARL's Auto Coding Tool Set**
  - <http://www.mcci-arl-va.com/>
- **Peak Ware**
  - <http://www.matra-msi.com/ang/savoir.htm>
- **Math Work's Matlab RTW RPD Tool**
  - <http://www.mathworks.com/>

## GEDAE Advantages

- Scheduler-BSP's parametric execution of the data flow
  - provides better processor independence
- Parametric parallelism
  - facilitates large scale parallelism